

P119 Control Valve



- Tight Shut-off
- Easy Installation
- Leak Detection
- Low Seat Leakage
- Gas or Liquid Service
- Inline Maintenance
- NACE Capability
- Low Temperature Version Available

The Type P119 Control Valve is versatile and can be used for on/off or throttling service. Springs range from 3-15 psi to 30-60 psi. The valve can be used in corrosive or non-corrosive gases or liquids, limited by available compatible materials. Maintenance on the valve can be accomplished without removing the valve body from the line (pressure must be removed and the valve isolated before attempting). A vent is provided in the valve actuator to detect leakage of actuator stem seals. Our combination disc assembly and seat offer positive shutoff at maximum body working pressure. NACE construction materials are standard for the steel body valve only, and comply with the National Association of Corrosion Engineers MR0175.

Applications

- On-Off or Throttling Control
- Heater Fuel Valve Control
- Gas Distribution

P119 Part Matrix

P119		0	0					
	▲	▲	▲	▲	▲	▲	▲	Port Size
	06							3/4 NPT
	08							1 NPT
	12							1-1/4 NPT*
								Spring Range
								PSIG BAR
	015							3 - 15 .20 - 1.03
	020							5 - 20 .34 - 1.38
	035							5 - 35 .34 - 2.41
	060							30 - 60 2.07 - 4.14
		0	0					Orifice
			2					1/8"
			3					3/16"
			4					1/4"
			5					5/16"
			6					3/8"
			8					1/2"
			9					9/16"
								Seat/Diaphragm Material
			00					Nitrile
			22					Fluorocarbon
			LL					Low Temperature Neoprene**
								**Must order LCC Body
								***Units with a Steel Body selection will automatically be provided with internal parts conforming to NACE MR0175. Orifice and Seat Housing will be made from 316SS.
								Body Material
			0					Iron
			2					Steel***
			6					LCC Steel****
								**** 1 NPT Only, NACE Standard

Materials of Construction

Component	Material
Body	Cast Iron, WCB Steel, LCC Steel
Housing	Aluminum
Bonnet	Aluminum
Disk Holder Assembly	Aluminum and Nitrile (standard), Stainless Steel and Nitrile, Stainless Steel and Fluoroelastomer, Aluminum and Fluoroelastomer, or Stainless Steel with Low Temperature Neoprene
Orifice	Aluminum (Standard) or 316 Stainless Steel
Diaphragm	Nitrile, Fluoroelastomer, or Low Temperature Neoprene
O-rings	Nitrile, (Standard) or Fluoroelastomer
Stem Wiper	TFE
Adjusting Screw	Steel
Spring	Steel



Specifications

Specification	Value
Body Sizes and End Connection Styles	3/4, 1 or 1-1/4 NPT screwed
Maximum Inlet Pressure	150 PSIG 10.3 BAR
Maximum Pressure Drop	150 PSIG 10.3 BAR For all port diameters
Maximum Housing Pressure	150 PSIG 10.3 BAR
Spring Ranges	See Table
Material Temperature Capabilities	With Nitrile Seat / Diaphragm -20 to 170 °F -29 to 77 °C
	With Fluoroelastomer Seat / Diaphragm 40° to 250°F 4.4 to 121 °C
	Low Temperature Version -40° to +170°F -40° to +77 °C
	Note: Not for use with hot water or ammonia.
Orifice Size and Flow Coefficients	See Table
Pressure Setting Adjustment	May be adjusted throughout each spring range by rotating the adjusting screw
Actuator Pressure Connection	1/4 NPT female
Spring Case and Bonnet Vents	1/4 NPT female
Weight	lbs. kg.
3/4"	4.8 2.2
1"	4.8 2.2
1-1/4"	4.7 2.1

P119 Flow Coefficients

Orifice Size		3/4 Inch Body	1 Inch Body	1-1/4 Inch Body
Inches	mm	C _v	C _v	C _v
1/8	3.2	0.45	0.45	0.45
3/16	4.8	0.93	0.93	0.93
1/4	6.4	1.6	1.6	1.6
5/16	7.9	2.7	2.7	2.7
3/8	9.5	3.3	3.4	3.6
1/2	12.7	4.6	5.0	5.7
9/16	14.3	5.7	6.0	7.0

P119 Spring Selection

Spring Range		Spring Part Number	Spring Color Code
PSIG	BAR		
3 - 15	0.2 - 1.0	655-689-000	Red
5 - 20	0.3 - 1.4	655-676-000	Silver
5 - 35	0.3 - 2.4	655-703-000	Blue
30 - 60	2.1 - 4.1	655-690-000	Green

P119 Gas Sizing Equation

$$C_v = (Q / 963) \sqrt{\frac{(SG)(T)}{(\Delta P)(P_1 + P_2)}}$$

C _v	Flow Coefficient
Q	Gas Flow Rate, (SCFH)
SG	Specific Gravity
P ₁	Inlet Pressure (PSIA)
P ₂	Outlet Pressure (PSIA)
Δ P	Pressure Drop, (PSI)
T	° Rankin (° F + 460)

Useful Conversions for Gas Flow

To Convert	Multiply By	To Obtain
SCFD	0.04167	SCFH
SCFS	3600	SCFH
SCFM	60	SCFH
M ³ /Hr.	35.34	SCFH
Lb./Hr.	19.52	SCFH
Kg./Hr.	43.04	SCFH

P119 Control Valve Rebuild Kits

	Part Number	Kit Includes
1/8" - 3/8" Orifice, Nitrile	971-P11-900	Diaphragm assembly, seat assembly, O-rings, hairpin clip, retaining ring and stem seal wiper.
1/2" - 9/16" Orifice, Nitrile	971-P11-901	
1/8" - 3/8" Orifice, Fluorocarbon	971-P11-902	
1/2" - 9/16" Orifice, Fluorocarbon	971-P11-903	
1/8" - 3/8" Orifice, Nitrile/NACE	971-P11-904	
1/2" - 9/16" Orifice, Nitrile/NACE	971-P11-905	
1/8" - 3/8" Orifice, Fluorocarbon/NACE	971-P11-906	
1/2" - 9/16" Orifice, Fluorocarbon/NACE	971-P11-907	
1/8" - 3/8" Orifice, Neoprene LL/NACE	971-P11-908	
1/2" - 9/16" Orifice, Neoprene LL/NACE	971-P11-909	

P119 Dimensions

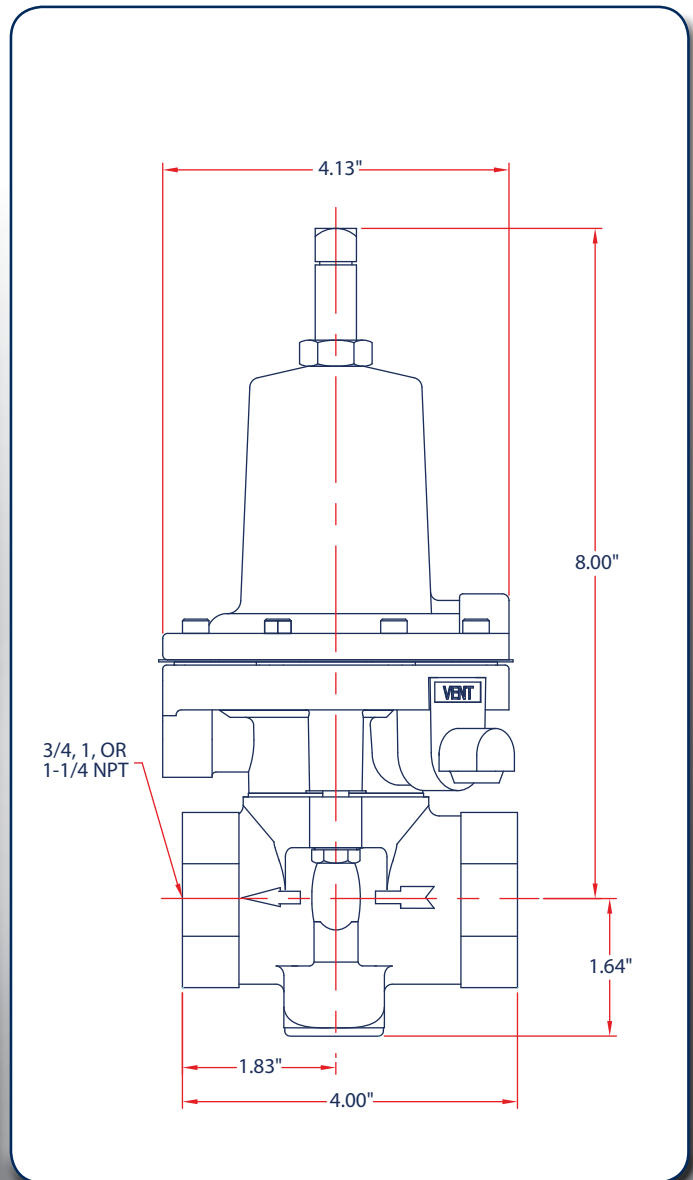

P119 Parts

Item	Description	Qty.	Part Number
1	Adjustment Screw	1	648-487-000
2	Lock Nut	1	634-179-000
3	Spring Guide	1	626-079-000
4	Range Spring	1	3-15 PSIG, Red
			5-20 PSIG, Silver
			5-35 PSIG, Blue
			30-60 PSIG, Green
5	Screen	1	647-023-000
6	Machined Bonnet	1	604-237-000
7	Housing	1	629-226-000
8	Bushing	2	608-074-000
9	Stem Wiper	2	649-305-000
10	Seat Assemblies Aluminum	1	Aluminum/Nitrile for 1/8" to 3/8" Orifice
			Aluminum/Fluorocarbon for 1/8" to 3/8" Orifice
			Aluminum/Nitrile for 1/2" & 9/16" Orifice
			Aluminum/Fluorocarbon for 1/2" & 9/16" Orifice
11	Seat Assemblies Stainless	1	316SS/Nitrile for 1/8" to 3/8" Orifice
			316SS/Fluorocarbon for 1/8" to 3/8" Orifice
			316SS/Neoprene (Low Temp) for 1/8" to 3/8" Orifice
			316SS/Nitrile for 1/2" & 9/16" Orifice
			316SS/Fluorocarbon for 1/2" & 9/16" Orifice
12	O-ring, (Stem)	2	Nitrile
			Fluorocarbon
13	Retaining Ring	2	644-057-000
14	Hair Pin - NACE	1	635-066-000
15	Orifice Aluminum	1	1/8"
			3/16"
			1/4"
			5/16"
			3/8"
			1/2"
16	Orifice 316 Stainless Steel	1	1/8"
			3/16"
			1/4"
			5/16"
			3/8"
			1/2"
17	Body	1	Steel - 3/4 NPT
			Steel - 1 NPT
			Iron - 3/4 NPT
			Iron - 1 NPT
			Iron - 1-1/4 NPT
18	Build Screws	8	LCC - 1 NPT
			664-392-001
19	O-ring, (Housing)	1	Nitrile
			Fluorocarbon
20	Vent Assembly	1	836-004-000
21	Body Bolts	2	Iron Body
			Steel Body
22	NACE Tag (Not Shown)	1	632-503-000
23	Lock Nut	1	634-180-000
24	Stem	1	Aluminum
			Stainless Steel
25	Washer, Flat	1	662-213-001
26	Washer	1	662-213-000
27	Diaphragms	1	Nitrile
			Fluorocarbon
28	Piston	1	637-306-000
29	Spring Retainer	1	643-191-000
30	Belleville Washer	1	662-212-000
31	Washer, StatOSeal	1	Nitrile
			Fluorocarbon
32	Disk, Teflon Fluorocarbon	1	619-056-000
33	Blank Label, Brady (Not Shown)	1	632-456-000

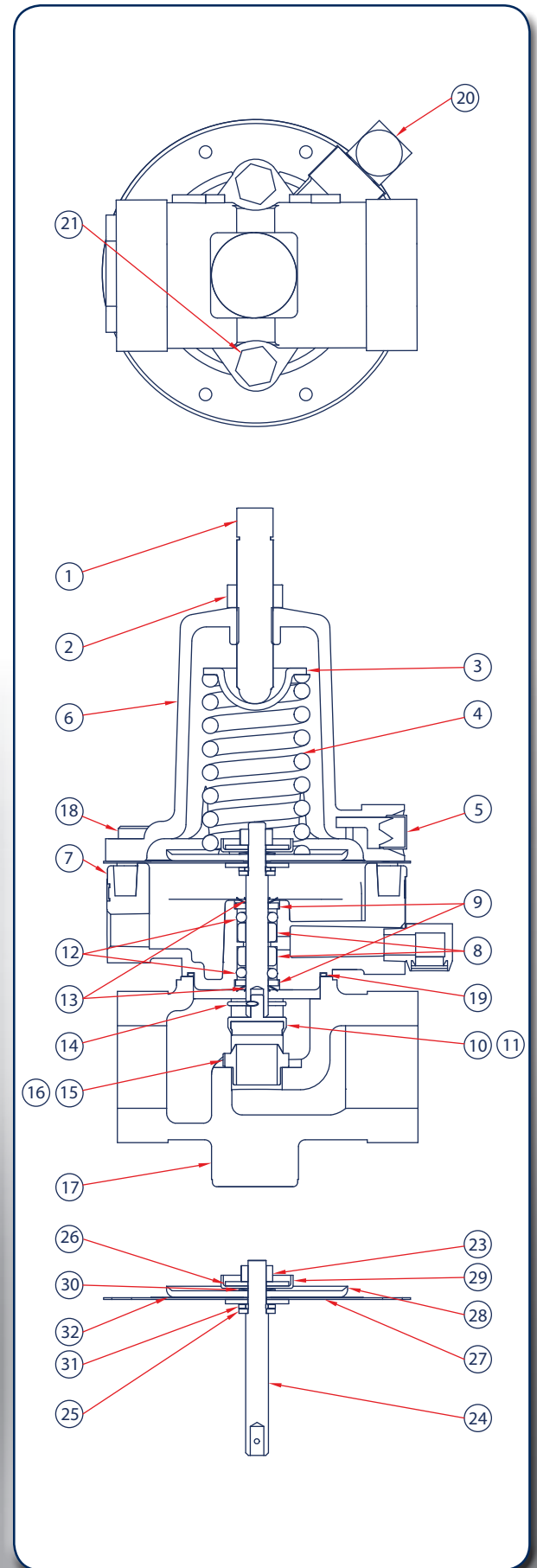

Notes:

